

Retáže s dutými čapmi

Hohlrollketten Rolltraktionen Kettenräder

nach Werksnorm
auch rosfrei

Hollow Pin Chains Roller Carrier Chains Sprockets

to work' standard
stainless steel too

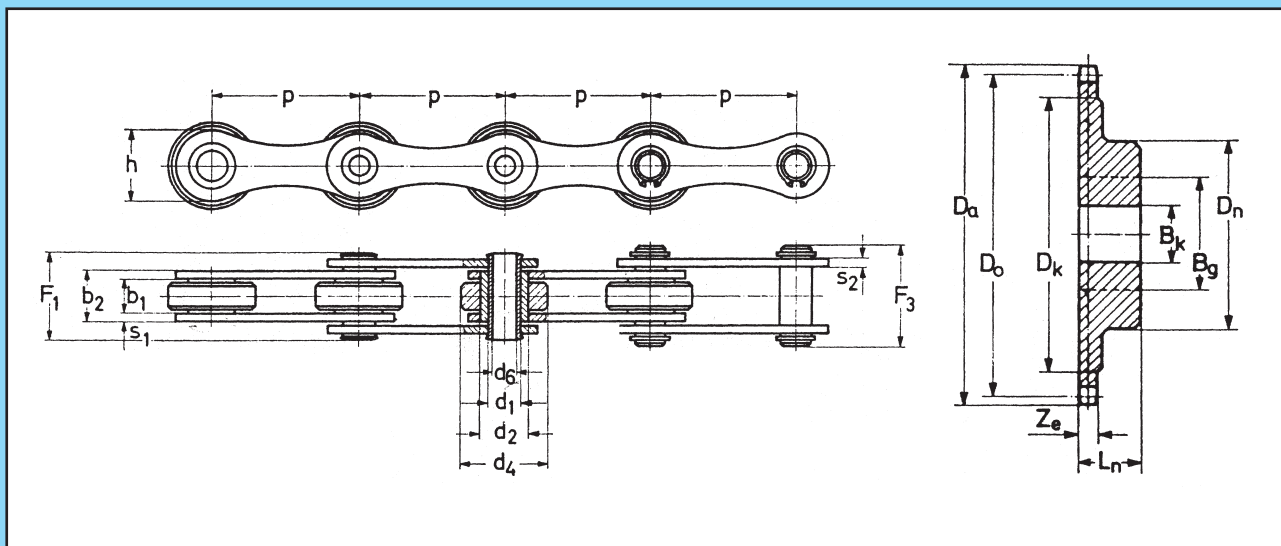

Tov. oz.	p mm	b ₁ mm min	b ₂ mm max	d ₁ mm	d ₂ mm	d ₄ mm	d ₆ mm	F ₁ mm min	F ₃ mm	h mm	s ₁ mm	s ₁ mm	f cm ²	F _B kN min	Q kg/m
64 040 000	50,0	10	16,8	11,6	16	30	8	26,6	30	25,4	3,0	3,0	1,95	500	2,25
64 055 000	50,8													500	2,17
64 060 000	50,8													600	2,17
64 100 000	100													500	1,50

Tov. oz.	Obj. čís.	p mm	z	Mat.	D ₀ mm	D _a mm	D _k mm	z _e mm	B _k mm	B _g mm	D _n mm	L _n mm	Q kg/m
	89 850 012	50,8	12	**	196,28	210	155	8,5	30	70	120	50	4,7
	89 850 018		18	**	292,55	305	250			70	120	70	8,7
	89 850 058		28	***	453,72	467	420			90	150	70	13,7
	89 850 018	100	9	**	292,55	305	250	8,5	30	70	120	70	8,7
	89 850 012		12	***	386,37	400	340			80	130		11,7
	89 850 018		18	***	575,88	590	535			90	150		20,5

f = Plocha kĺbu
F_B = Pevnosť pri pretrhnutí
Q = Hmotnosť reťaze

f = Gelenkfläche
F_B = Bruchkraft
Q = Kettengewicht

f = Bearing area
F_B = Breaking load
Q = Chain weight