

Štandardné reťazové kolesá

pre jednoradové valčekové reťaze

Standard-Kettenräder

für Einfach-Rollenketten

Standard Sprockets

for simple roller chains

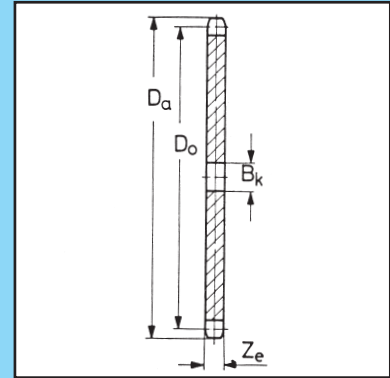
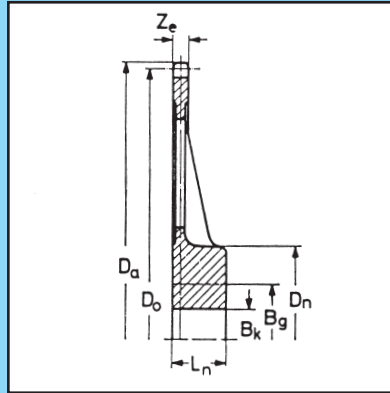
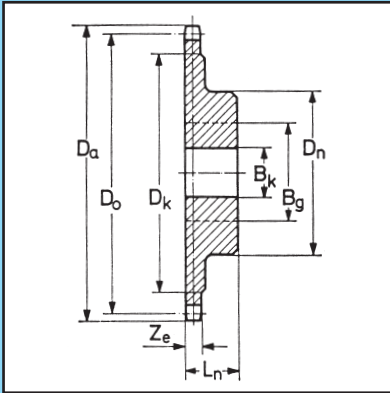

ISO Nr.	p mm	Art. Nr.	z	Mat.	D _o mm	D _a mm	D _k mm	z _e mm	B _k mm	B _g * mm	D _n mm	L _n mm	q
04-1			8		15,67	18,0			5		9,8	10	
			9		17,54	19,9			5		11,5	10	
			10		19,42	21,7		2,6	6		13	10	
			11		21,30	23,6			6		14	10	
			12		23,18	25,4			6		16	10	
			13		25,05	27,3			8		18	10	
			14		26,96	29,2			8		20	10	
			15		28,86	31,0			8		20	10	
			16		30,76	33,0			8		20	13	
			17		32,65	35,0			8		20	13	
			18		34,55	36,9			8		20	13	
			19		36,44	38,8			8		20	13	
			20		38,34	40,7			8		20	13	
			21		40,25	42,6			8		25	13	
			22		42,16	44,5			8		25	13	
			23		44,06	46,4			8		25	13	
			24		45,96	48,3			6		25	13	
			25		47,87	50,2			8		25	13	
			26		49,76	52,1			8		30	15	
			27		51,67	54,0			8		30	15	
			28		53,58	55,9			8		30	15	
			29		55,50	57,8			8		30	15	
			30		57,42	59,8			8		30	15	
			31		59,31	61,7			8		30	15	
			32		61,21	63,6			8		30	15	
			33		63,11	65,5			8		30	15	
			34		65,02	67,4			8		30	15	
			35		66,93	69,3			8		30	15	
			36		68,84	71,2			8		30	15	
			37		70,75	73,1			6		30	15	
			38		72,66	75,0			8		30	15	
			39		74,57	76,9			8		30	15	
			40		76,47	78,9			6		30	15	
			45		86,01	88,5			10		40	16	
			50		95,55	98,0			12		50	20	
			57		108,93	111,4			12		50	20	
			76		145,19	147,6			12		60	20	
05 B-1	8	89 175 017	17	**	43,54	47	34		8	20	34	16	0,13
		89 175 019	19		48,60	52	39		8	25	39	16	0,16
		89 175 038	38		96,88	101	87	2,8	10	35	60	25	0,70
		89 175 057	57		145,22	148	136		10	35	60	25	1,00
		89 175 076	76		193,59	197	184		10	35	60	25	1,50
06 B-1			8		24,89	28,0	15		6		15	22	
			9		27,85	31,0			8		18	22	
			10		30,82	34,0			8		20	22	
	9,525	89 201 011	11	**	33,81	37	21	5,2	10	15	21	22	0,10
		89 201 012	12		36,80	40	24		10	15	24	22	0,11
		89 201 013	13		39,80	43	28		10	15	28	24	0,12
		89 201 014	14		42,81	46	31		10	18	31	24	0,15
		89 201 015	15		45,81	49	34		10	20	34	24	0,18
		89 201 016	16		48,82	52	37		10	22	37	24	0,24
		89 201 017	17		51,84	55	40		10	25	40	28	0,29
		89 201 018	18		54,85	58	43		10	28	43	28	0,34
		89 201 019	19		57,87	61	46		10	30	46	28	0,38
		89 201 020	20		60,89	65	49		10	32	49	28	0,43
		89 201 021	21		63,91	67	52		10	32	52	28	0,47
		89 201 022	22		66,93	70	56		10	34	55	28	0,53
		89 201 023	23		69,95	73	58		10	35	58	28	0,59
		89 201 024	24		72,97	76	61		10	38	61	28	0,65
		89 201 025	25		76,00	80	64		10	40	64	28	0,72
		89 201 026	26		79,02	83	67		10	45	67	28	0,78
			27		82,5	86,0			12		60	60	
			28		85,07	89,0			12		60	28	
			29		88,09	92,0			12		60	28	

* = Rozmer B_g je približná hodnota

q = hmotnosť v kg/kus

z = počet zubov